

HONDA MOTORCYCLE CARBURETION

CONTENTS

SUBJECT	PAGE
AIR-FUEL RATIOS	2
BASIC PRINCIPLES OF CARBURETOR OPERATION	3 - 5
Atomizer Principle	3
Venturi Effect	3 - 4
Choke Effect	4 - 5
FLOAT SYSTEM.	6 - 9
Float System Components and Operation	6
Eccentric Float Chamber	7 - 8
Concentric Float Chamber	8
Float Adjustment.	9
THROTTLE VALVE	10 - 12
Disc Throttle Valve	10
Slide Throttle Valve.	10
Maintaining Correct Air-Fuel Mixture Ratios	11
Throttle Valve Synchronization	11 - 12
AIR-BLEEDS	12 - 13
Main Jet Air-Bleed	12
Idle and Low Speed Air-Bleed	13
Altitude Compensator	13
IDLE AND LOW SPEED SYSTEM	14 - 16
Fuel Discharge Orifices	14
Idle and Low Speed Air-Fuel Mixture Adjustment	15
Idle Speed Adjustment	16
INTERMEDIATE SYSTEM WITH SLIDE TYPE THROTTLE VALVE	17 - 18
Throttle Valve Cutaway	17 - 18
Jet Needle	18
INTERMEDIATE SYSTEM WITH DISC TYPE THROTTLE VALVE AND VACUUM PISTON	19 - 22
Vacuum Piston Construction	19 - 20
Vacuum Piston Operation	20
Acceleration.	21
Jet Needle	21
Main Jet Fuel Circuits	22
INTERMEDIATE SYSTEM WITH COMBINATION SLIDE TYPE THROTTLE VALVE/VACUUM PISTON	23 - 24
Construction	23
Operation.	23 - 24
HIGH SPEED SYSTEM	24
FUEL MIXTURE CONTROL IN RELATION TO THROTTLE POSITION	25
COLD STARTING SYSTEM	26 - 27
Choke Valve.	26
Mixture Enrichener	27
CARBURETOR TROUBLESHOOTING CHART	28 - 29

MOTORCYCLE CARBURETION

The function of the carburetor is to atomize fuel and mix it with air in proper proportions to suit engine operating conditions. In operation, the carburetor sprays gasoline into the air passing through it. The atomized gasoline (a mist of liquid fuel) is then vaporized by engine heat and heat of compression to provide a uniform and efficiently combustible air-fuel mixture.

The quantity of gasoline dispensed by the carburetor is controlled by metering circuits within the carburetor body, providing exactly the right air-fuel ratios. A throttle valve controls the amount of air-fuel mixture delivered to the engine, regulating the engine's power output.

AIR-FUEL RATIOS

The theoretically perfect air-fuel ratio is 15 parts of air to 1 part of gasoline, by *weight*. When there is a uniform air-fuel ratio of this proportion, the mixture burns completely without leaving an excess of either fuel or air.

The air-fuel mixture may still burn effectively when the ratio is as rich as 7:1 or as lean as 20:1. The actual limits of combustion will vary according to combustion chamber shape, pressures, temperatures, fuel characteristics, and mixture uniformity.

Extremely rich and extremely lean fuel mixtures both result in loss of power. An extremely rich fuel mixture burns slowly and incompletely, because there is not enough oxygen in the air to combine with the fuel. Incomplete fuel combustion causes spark plug fouling and carbon build-up in the combustion chamber. An extremely lean fuel mixture burns slowly and does not use all the oxygen in the air. If the lean fuel mixture is still burning when the exhaust valve opens, the valve head is exposed to prolonged high temperatures and oxygen, which may result in a burnt valve. Prolonged high cylinder temperatures may also lead to pre-ignition and may melt the piston crown.

Under actual operating conditions, fuel vaporization and combustion are less than perfect. Consequently, maximum power is usually developed with an air-fuel ratio of about 12:1 rather than the theoretical optimum of 15:1.

A very rich air-fuel mixture is required for cold starting because a cold engine reduces vaporization and causes fuel condensation on the intake ports and cylinder walls.

BASIC PRINCIPLES OF CARBURETOR OPERATION

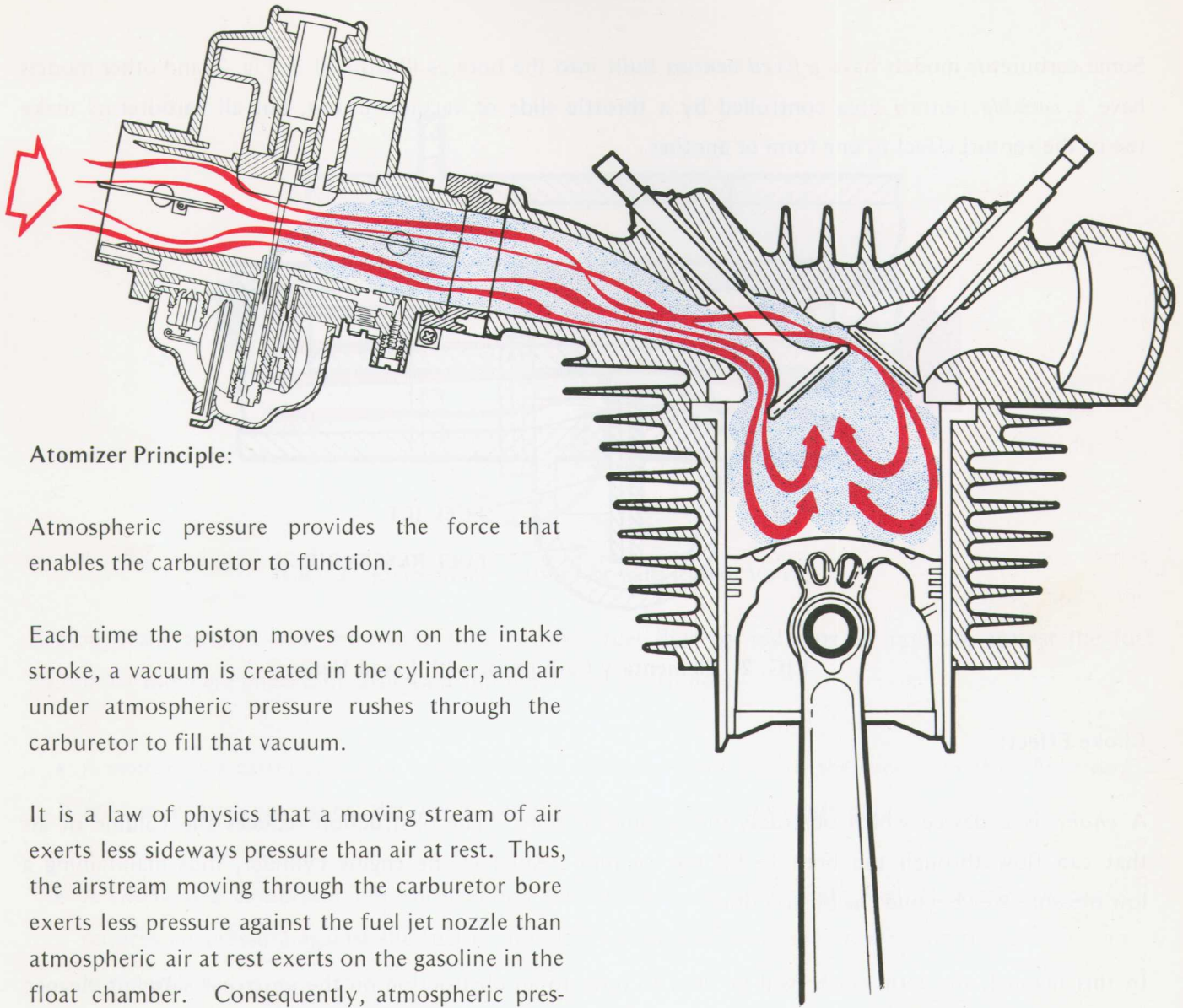

Atomizer Principle:

Atmospheric pressure provides the force that enables the carburetor to function.

Each time the piston moves down on the intake stroke, a vacuum is created in the cylinder, and air under atmospheric pressure rushes through the carburetor to fill that vacuum.

It is a law of physics that a moving stream of air exerts less sideways pressure than air at rest. Thus, the airstream moving through the carburetor bore exerts less pressure against the fuel jet nozzle than atmospheric air at rest exerts on the gasoline in the float chamber. Consequently, atmospheric pressure forces gasoline up the jet, spraying it into the airstream in the carburetor bore.

A spray gun used in painting, and a perfume atomizer, operate on the same principle.

Venturi Effect:

A *venturi* is a constriction in the carburetor bore in the immediate area of the fuel jet nozzle. This constriction makes the atomizer principle work more effectively. Because the carburetor bore is narrower at the venturi, the volume of air passing through the bore must move faster at this point than at other areas. Increasing the speed of the airstream at the fuel jet nozzle decreases air pressure against the nozzle, causing atmospheric pressure in the fuel reservoir to force more fuel into the carburetor bore.

FIG. 1

BASIC PRINCIPLES OF CARBURETOR OPERATION (continued)

Some carburetor models have a *fixed venturi* built into the bore as illustrated in Fig. 2, and other models have a *variable venturi* area controlled by a throttle slide or vacuum piston, but all carburetors make use of the venturi effect in one form or another.

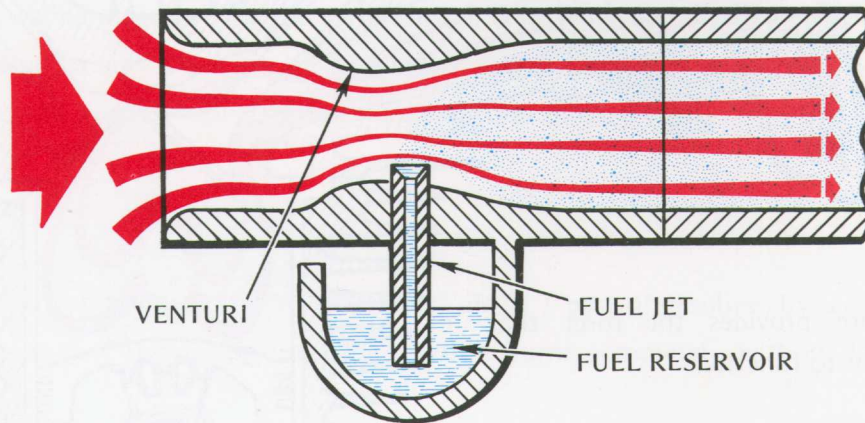

FIG. 2 Elementary Carburetor with Fixed Venturi

Choke Effect:

A *choke* is a device which obstructs the carburetor bore. The obstruction reduces the volume of air that can flow through the bore to fill the vacuum created in the engine cylinder, thus maintaining a low pressure area beyond the obstruction.

In this manual, the term *choke* will be used to refer to an obstruction on the *upstream* side (air cleaner side) of the fuel jet nozzle, as opposed to the term *throttle* which will refer to a *central* or *downstream* obstruction.

Because the choke is located on the upstream side of the fuel jet nozzle, the nozzle is within the low pressure area, causing atmospheric pressure in the fuel reservoir to force more fuel into the carburetor bore.

The most familiar application of a choke is the choke valve used to enrich the cold starting mixture, but the choke effect may also be utilized in other systems of the carburetor; for example, the upstream edge of a slide type throttle valve exerts a choking effect (see Throttle Valve Cutaway, page 17).

BASIC PRINCIPLES OF CARBURETOR OPERATION (continued)

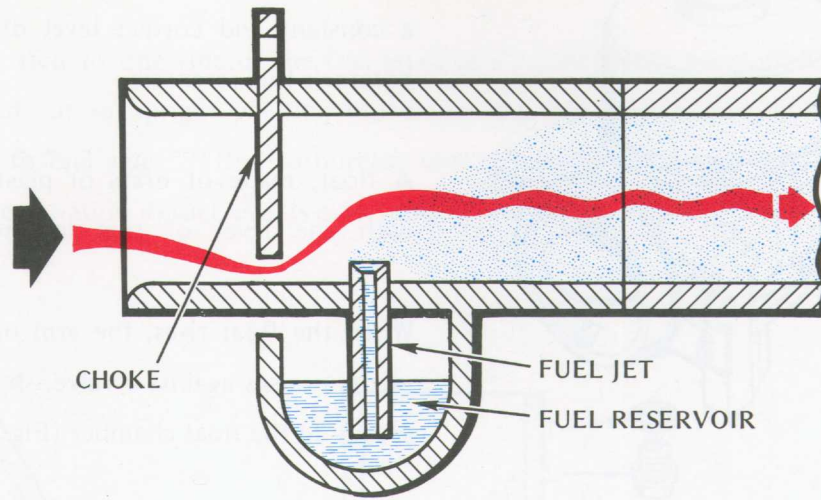

FIG. 3 Elementary Carburetor with Choke Valve

Although the *venturi* and the *choke* both increase fuel flow by reducing air pressure against the fuel jet nozzle, there are important structural and functional differences:

- A *venturi* is a carburetor bore *constriction* in the *immediate area* of the fuel jet nozzle. A *venturi* reduces air pressure against the fuel jet nozzle by *locally increasing airstream velocity*.
- A *choke* is a carburetor bore *obstruction* on the *upstream* side of the fuel jet nozzle. A *choke* reduces air pressure against the fuel jet nozzle by *preventing atmospheric air from filling induction port vacuum*.

The elementary carburetor illustrated in Fig. 2 would be capable of sustaining an engine at a constant high rpm, as long as the operator supplied fuel to the reservoir at the base of the jet. However, such a simplistic design lacks the features needed for control of engine rpm and flexible response to different operating conditions.

For practical operation, the carburetor must have a float system to control the fuel level at the base of the jets (or an alternative system such as the pressure pulse diaphragm), a throttle valve to regulate the volume of air-fuel mixture delivered to the engine, fuel metering systems to suit all operating conditions, and a choke valve or mixture enricher to facilitate cold starting.

FLOAT SYSTEM

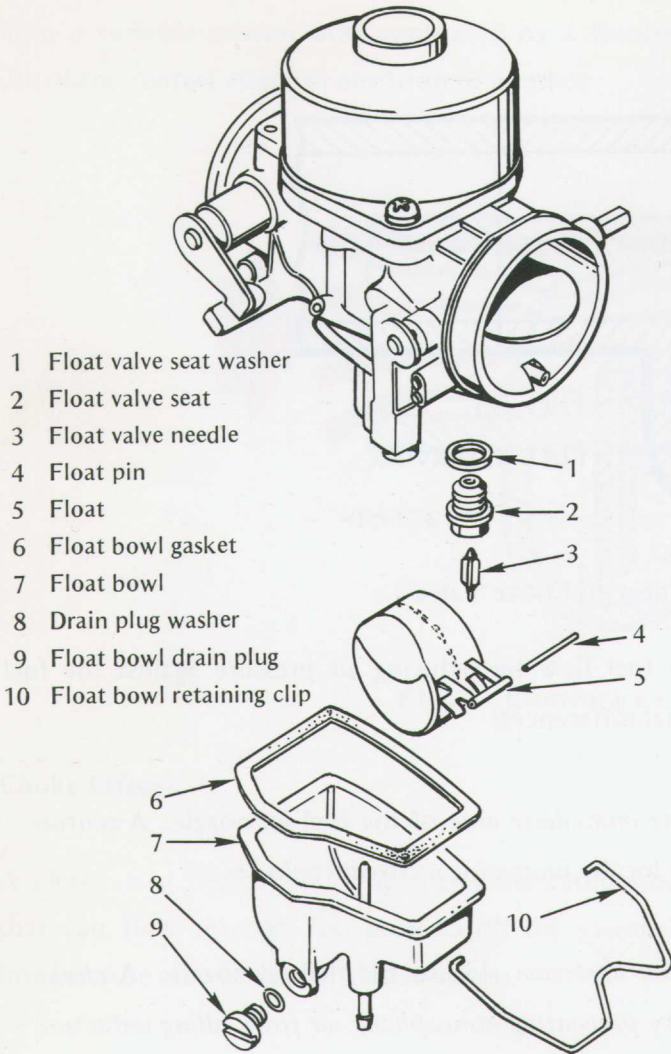

FIG. 4 Float System Components

The purpose of the float system is to maintain a constant and correct level of fuel in the carburetor's fuel reservoir.

A float, made of brass or plastic, rises and falls with the level of fuel in the float chamber.

When the float rises, the arm on which the float pivots presses against a valve, shutting off the fuel supply to the float chamber (Fig. 5).

When the float falls, the float arm releases the valve, allowing fuel to enter the float chamber (Fig. 6).

The float arm is adjusted to close the valve when the fuel reaches exactly the right level. If the fuel level should rise above the correct level, too much fuel may be released into the carburetor bore, resulting in a rich air-fuel mixture. If the fuel level should fall below the correct level, too little fuel may reach the carburetor bore, resulting in a lean mixture.

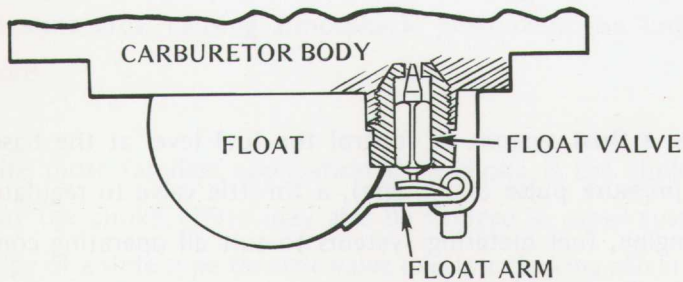

FIG. 5 Float Valve Closed

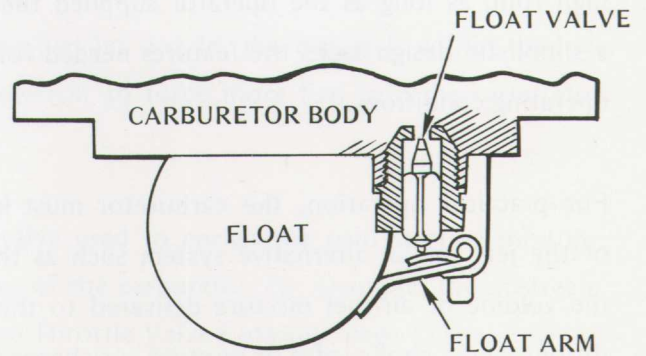

FIG. 6 Float Valve Open

FLOAT SYSTEM (continued)

Eccentric Float Chamber:

A single float, located to one side of the fuel jet (Fig. 7) maintains a constant fuel level in the jet while the machine stands in an upright position but causes the fuel level in the jet to rise or fall when the machine is tilted to one side. If the carburetor uses a separate float chamber, mounted to one side of the carburetor, the variation in fuel level is even more pronounced.

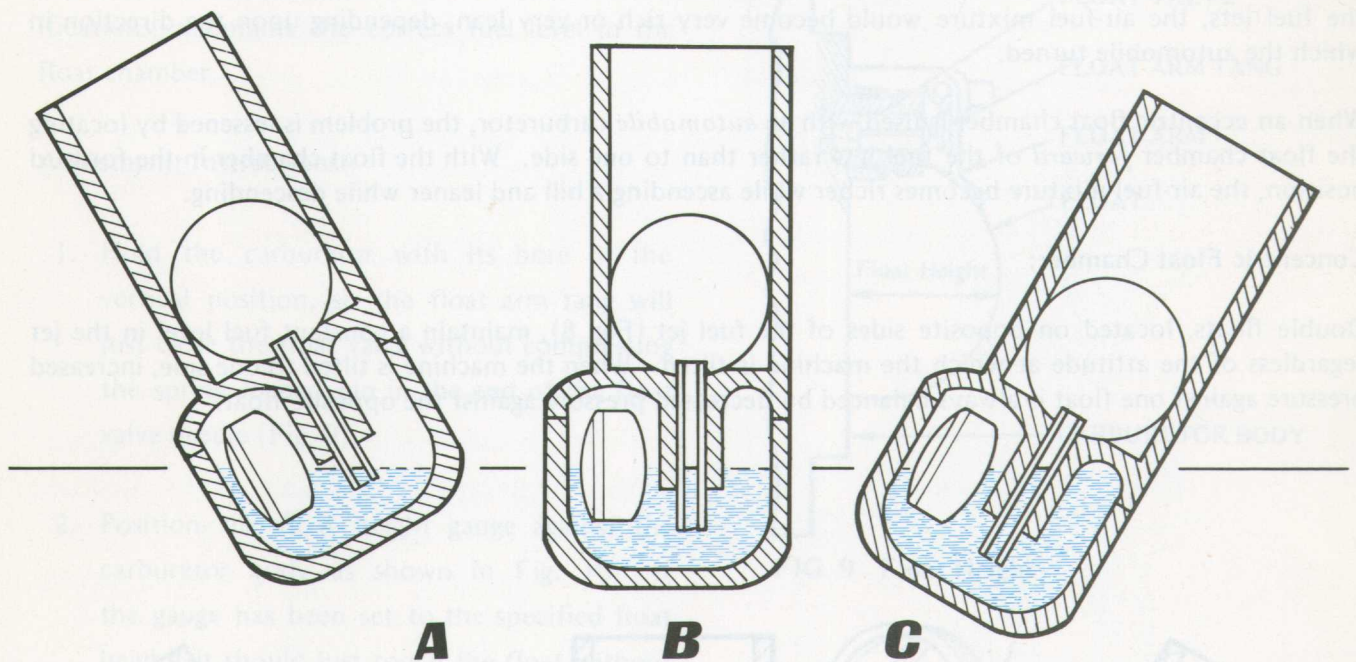

FIG. 7 Eccentric Float Chamber

In Fig. 7B, the motorcycle is standing upright. When fuel enters the float chamber, the float rises to the position illustrated and closes the float valve. The fuel level is maintained at the height shown.

When fuel enters the float chamber with the motorcycle tilted as shown in Fig. 7A, the float will be raised to the closed position before the fuel level rises to the correct height in the jet.

When fuel enters the float chamber with the motorcycle tilted as shown in Fig. 7C, the float will not be raised to the closed position until the fuel level rises above the correct height in the jet.

FLOAT SYSTEM (continued)

Fuel levels shown in Fig. 7A, B, & C apply when the motorcycle is at rest or operated in a straight line. Under those conditions, gravity is the controlling force. When the motorcycle negotiates a curve in the road, however, centrifugal force also affects the level of the fuel.

When ridden through a curve in the road, the motorcycle is leaned to the inside of the curve to a point where the combination of gravitational force and centrifugal force acts through the plane of the wheels. Fortunately, this combination of forces also serves to keep the fuel level in the carburetor perpendicular to the jet, as shown in Fig. 7B.

Because a motorcycle is leaned to the inside of the curve when cornering, an eccentric float chamber located to one side of the fuel jet will maintain the correct fuel level in the jet under most operating conditions.

If an eccentric float chamber, located to one side of the jet, were to be used in an *automobile*, centrifugal force while cornering would pose a problem. Because an automobile does *not* lean to the inside of the curve, fuel is sloshed to one side of the float chamber. If the float chamber were located to one side of the fuel jets, the air-fuel mixture would become very rich or very lean, depending upon the direction in which the automobile turned.

When an eccentric float chamber is used with an *automobile* carburetor, the problem is lessened by locating the float chamber *forward* of the fuel jets rather than to one side. With the float chamber in the forward position, the air-fuel mixture becomes richer while ascending a hill and leaner while descending.

Concentric Float Chamber:

Double floats, located on opposite sides of the fuel jet (Fig. 8), maintain a constant fuel level in the jet regardless of the attitude at which the machine is tilted. When the machine is tilted to one side, increased pressure against one float is always balanced by decreased pressure against the opposite float.

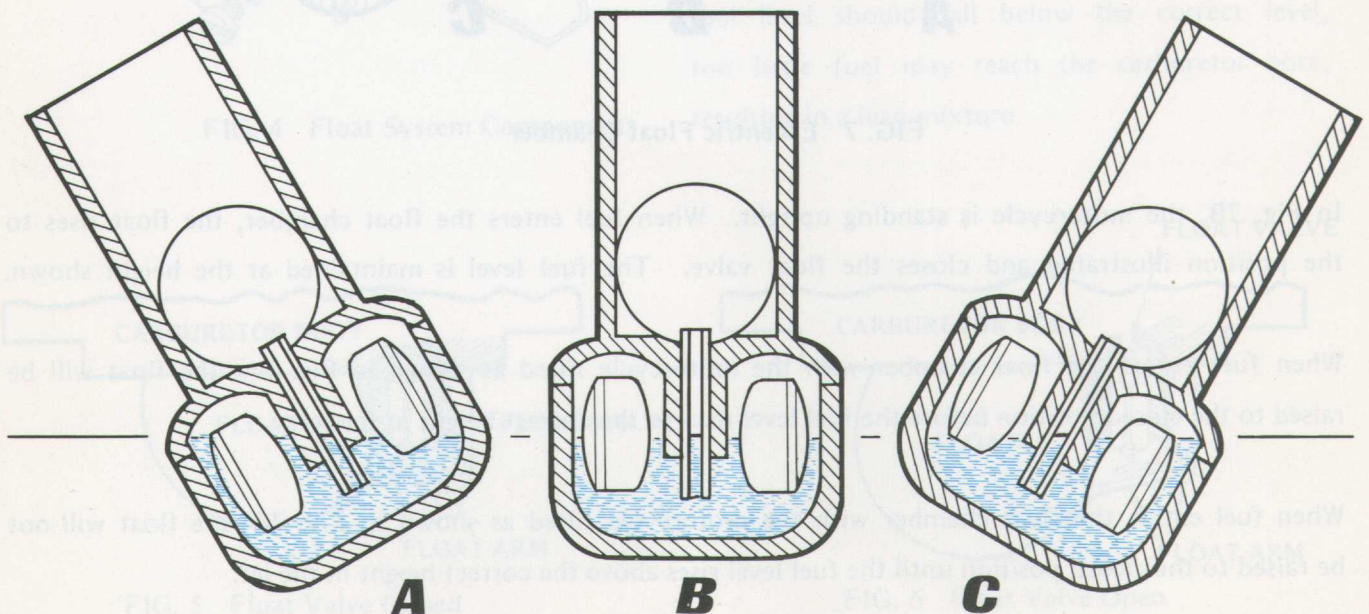

FIG. 8 Concentric Float Chamber

FLOAT SYSTEM (continued)

Float Adjustment:

The correct float chamber fuel level is established by the carburetor manufacturer in accordance with the design, characteristics, and application of the particular carburetor model.

Because it is not possible to see the actual level of the fuel within the float chamber (unless one attaches a sight tube), float adjustment specifications are usually given in terms of the distance between the carburetor body and the bottom of the float when the float arm just closes the valve (Fig. 9).

Float height, adjusted to the manufacturer's specifications, maintains the correct fuel level in the float chamber.

Adjustment Instructions:

1. Hold the carburetor with its bore in the vertical position, so the float arm tang will just close the float valve without compressing the spring loaded pin in the end of the float valve needle (Fig. 9).
2. Position the float height gauge against the carburetor body as shown in Fig. 10. If the gauge has been set to the specified float height, it should just touch the float without causing the float to move.
3. If float height is found to be incorrect, carefully bend the float arm tang toward or away from the float valve until the specified float height is obtained.

When adjusting carburetors equipped with double floats, measure both floats to be certain they are of equal height. Slight misalignment between double floats can be corrected by carefully twisting the float arm. Floats which are damaged or severely misaligned must be replaced.

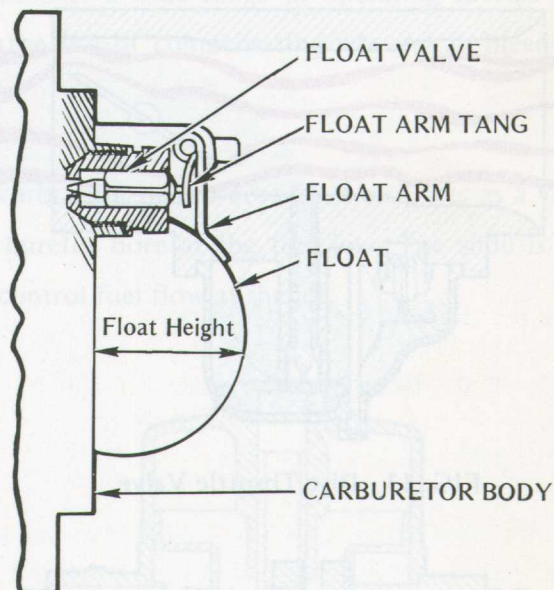

FIG. 9 Float Height

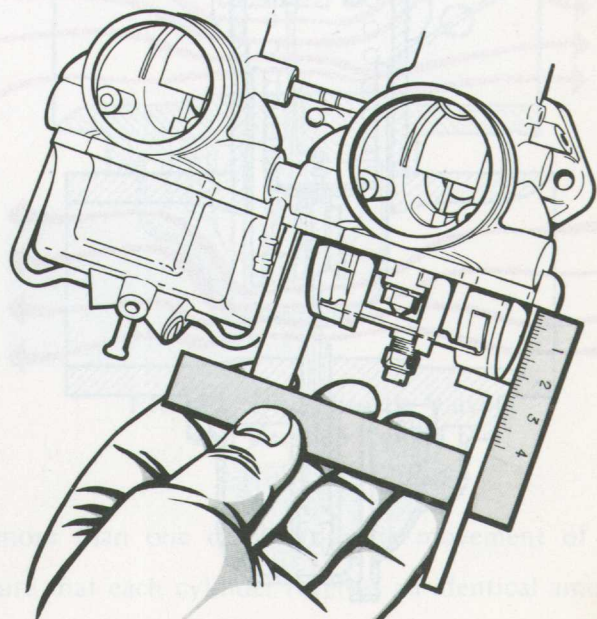

FIG. 10 Float Height Gauge

THROTTLE VALVE

The throttle valve regulates the engine's power output by controlling the volume of air-fuel mixture delivered to the engine cylinder. Reducing the charge in the cylinder reduces the power it can generate and vice versa.

Throttle valves used in motorcycle carburetors are commonly either disc (butterfly) type or cylindrical slide type. Other throttle valve shapes (e.g. flat slide) have been utilized but are not commonly encountered.

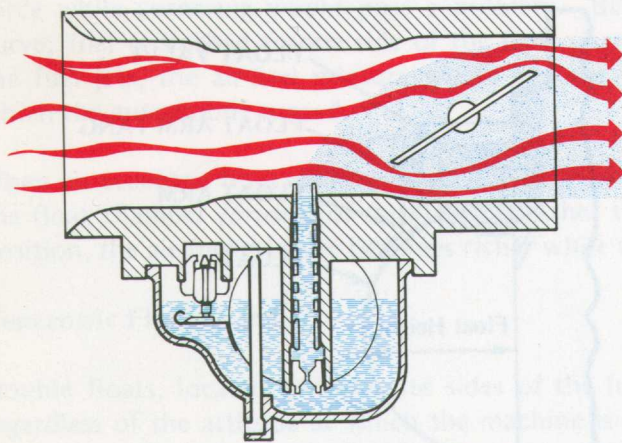

FIG. 11 Disc Throttle Valve

Disc Throttle Valve:

Because the disc throttle valve rotates on a central axis, it is balanced against pressure. This type of throttle valve opens and closes freely regardless of induction pressure fluctuations or pressure differences on either side of the valve. Disc throttle valves are used in automobile carburetors and in some motorcycle carburetors.

Slide Throttle Valve:

Slide type throttle valves require fluctuating induction pressures in order to work freely and easily without unusually strong closing springs. Steady induction pressures press the throttle slide against one side of its guide, which increases closing friction.

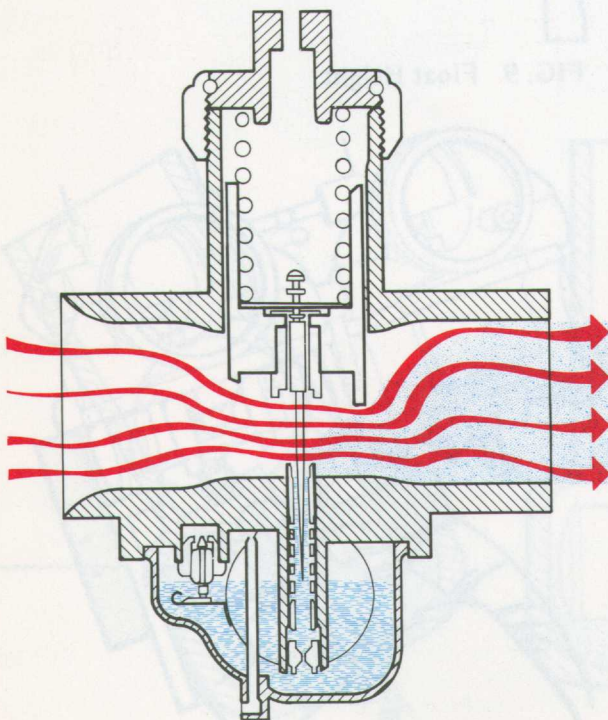

FIG. 12 Slide Throttle Valve

For this reason, slide type throttle valves are not suitable for the multi-cylinder manifolds used in automobile engines but work very well in motorcycle applications where each carburetor feeds only one or two cylinders. Manifold vacuum fluctuates greatly where there is no overlap between intake strokes in the engine.

THROTTLE VALVE (continued)

Maintaining Correct Air-Fuel Mixture Ratios:

The air-fuel mixture ratio is affected by changes in venturi air speed. When the throttle valve opening is increased and engine rpm also increases, air will rush through the carburetor bore at a greater rate. Unfortunately, the rate of fuel flow through a fixed jet does not increase proportionately with an increase in air speed through a fixed venturi. At high speeds, the air-fuel mixture ratio tends to become richer. It is therefore desirable to provide some means of varying the venturi size and metering fuel flow in order to maintain correct air-fuel mixture ratios over a wide range of operating speeds. Alternatively, this objective can also be achieved solely by the use of compensating jets and air-bleeds, as is done in many automobile carburetors.

The use of a slide type throttle valve helps to simplify carburetor design because it also acts as a variable venturi. As the slide is lowered, it constricts the carburetor bore at the fuel jet. The slide is also a very convenient mount for holding a metering needle to control fuel flow at the jet.

A disc throttle valve is located beyond the venturi area and obviously creates no constriction at that point. If a carburetor using a disc throttle valve had only one fixed jet and one fixed venturi, as in Fig. 11, it could deliver the correct air-fuel mixture ratio at only one air speed. Therefore, when a disc throttle valve is used, the carburetor must also be equipped with compensating systems, or a vacuum piston to vary venturi size and hold a fuel metering needle (Fig. 13) in the manner of a slide throttle. The vacuum piston possesses some special advantages, however, which will be explained in later sections of this manual.

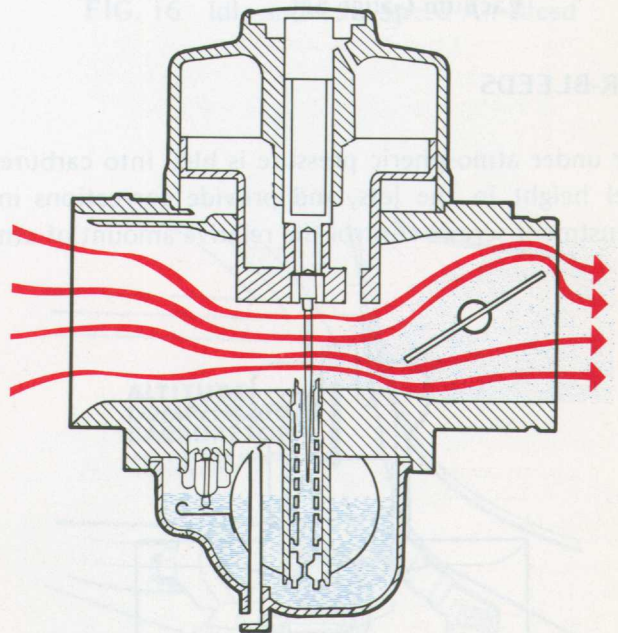

FIG. 13 Disc Throttle Valve and Vacuum Piston

Throttle Valve Synchronization:

On multi-cylinder and twin cylinder engines using more than one carburetor, the movement of the throttle valves must be accurately synchronized to ensure that each cylinder receives an identical amount of fuel mixture.

THROTTLE VALVE (continued)

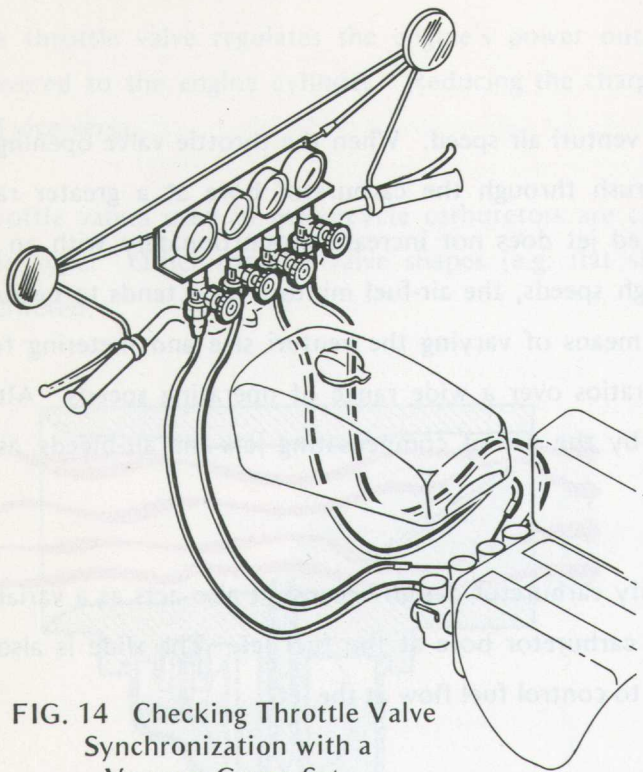

FIG. 14 Checking Throttle Valve Synchronization with a Vacuum Gauge Set

AIR-BLEEDS

Air under atmospheric pressure is bled into carburetor fuel passages to improve fuel atomization, stabilize fuel height in the jets, and provide corrections in the air-fuel mixture ratio. Air jets and/or air-bleed adjustment screws control the relative amount of atmospheric air drawn into the fuel systems.

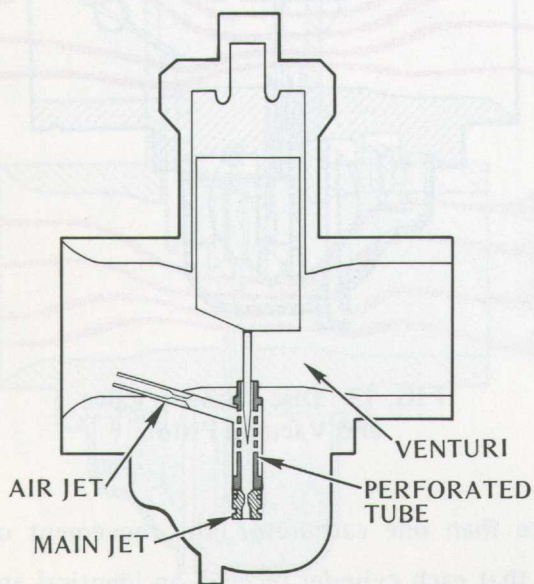

FIG. 15 Main Jet Air-Bleed

Throttle valve synchronization in twin cylinder engines can be judged by placing one's hands at the tips of the mufflers. If the exhaust pressure feels equal in both pipes, the throttle valves are synchronized within acceptable limits. A more accurate measure of synchronization can be made with a vacuum gauge set if the engine is tapped to receive vacuum gauge attachments, or with an air flow meter if a vacuum gauge set cannot be attached.

Throttle valve synchronization in Honda four cylinder engines requires the use of a vacuum gauge set. Four throttle valves cannot be accurately synchronized by feel, and it is inconvenient to use an air flow meter on these models.

Specific instructions for throttle valve synchronization adjustment are given in the applicable shop manuals.

Main Jet Air-Bleed:

Fig. 15 illustrates a typical main jet air-bleed. Low venturi pressure, which causes fuel to rise through the main fuel jet, also causes atmospheric air to flow through the air jet. Air and fuel meet and mix together in a perforated tube above the main fuel jet. The aerated fuel released into the venturi is more easily atomized than a dense unaerated stream of fuel.

Aerated fuel also has less tendency to fall back down the jet tube between intake strokes, thus stabilizing fuel height in the jet tube. The same effect can be observed when drinking beverages through a straw. When you remove your mouth from the straw, a frothy beverage tends to remain in the straw, but an unaerated beverage will fall back down the straw into the cup.

AIR-BLEEDS (continued)

Idle and Low Speed Air-Bleed:

Fig. 16 illustrates an idle and low speed air-bleed provided with an adjustment screw for controlling the flow of air delivered to the perforated tube above the low speed fuel jet. The screw can be turned to constrict the air-bleed passage, producing a richer pre-mixture, and vice versa.

The majority of motorcycle carburetors are provided with this type of air-bleed screw for adjusting idle mixture. However, some models have a fixed idle and low speed air-bleed and use an adjustment screw to meter the flow of aerated fuel instead.

Altitude Compensator:

The atmosphere is less dense at high altitudes than at sea level. The weight of air in the air-fuel mixture at high altitudes is therefore reduced, causing the mixture to become excessively rich.

When a vehicle is operated at high altitudes, the air-fuel mixture ratio can be corrected by installing smaller diameter fuel jets to reduce fuel flow in proportion to the reduced weight of air. Alternatively, air-bleeds can be provided to correct the air-fuel mixture ratio without necessitating fuel jet replacement.

The carburetor on Honda CT-90, ST-90, and ATC-90 models is equipped with an *altitude compensator* for use at 6000 ft. above sea level or higher. When the compensator knob is pulled outward, an auxiliary air-bleed comes into operation and supplies additional air to both main and low speed fuel systems.

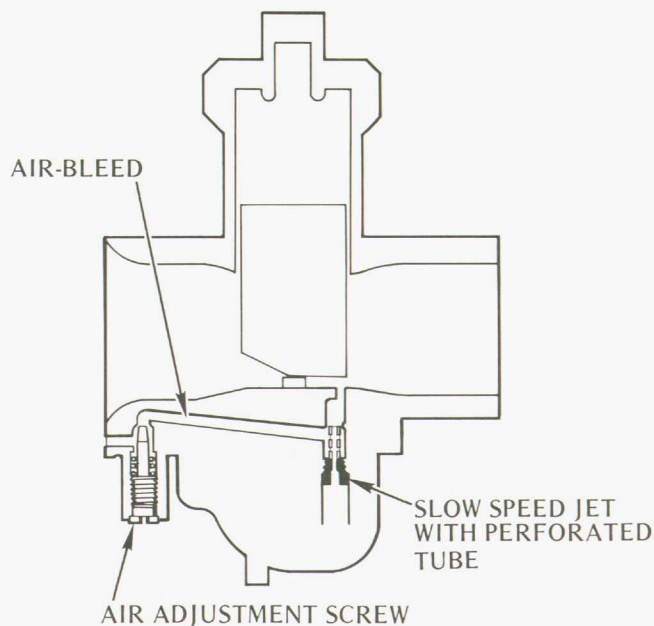

FIG. 16 Idle and Low Speed Air-Bleed

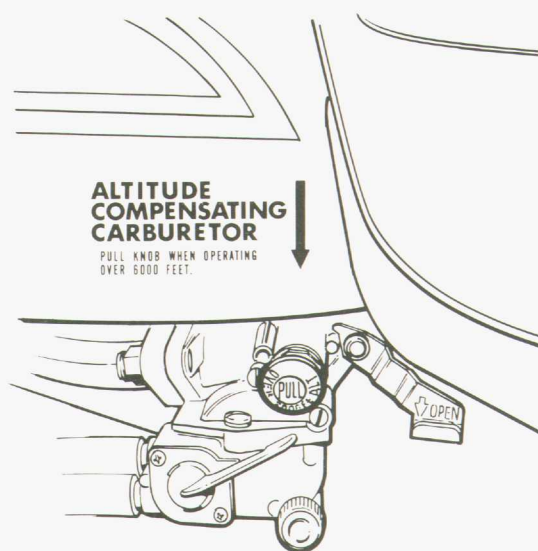

FIG. 17 Altitude Compensator

IDLE AND LOW SPEED SYSTEM

If the engine were equipped with one of the carburetors illustrated in Fig. 11, 12, or 13, it would cease to run when the throttle valve approached the closed position.

When the throttle valve is at or near the closed position, very little air can flow through the carburetor bore. The air moves too slowly across the main jet for the atomizer principle to work effectively, and no fuel is delivered from that jet. It is therefore necessary for the carburetor to have a separate fuel system for idle and low speed operation.

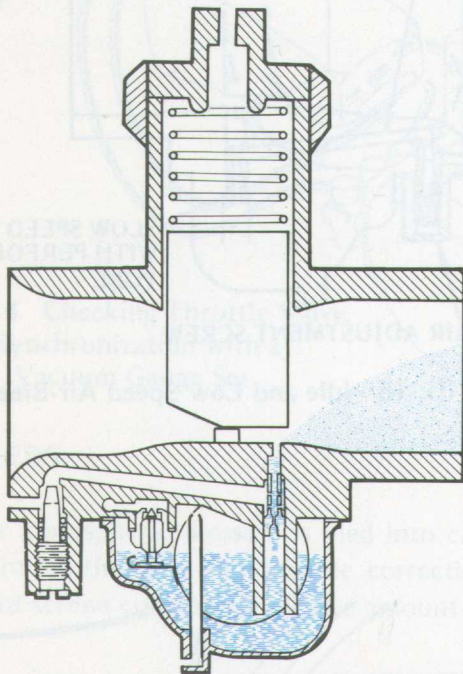

FIG. 18 Idle and Low Speed System with Air-Bleed Adjustment Screw and Single Fuel Discharge Orifice

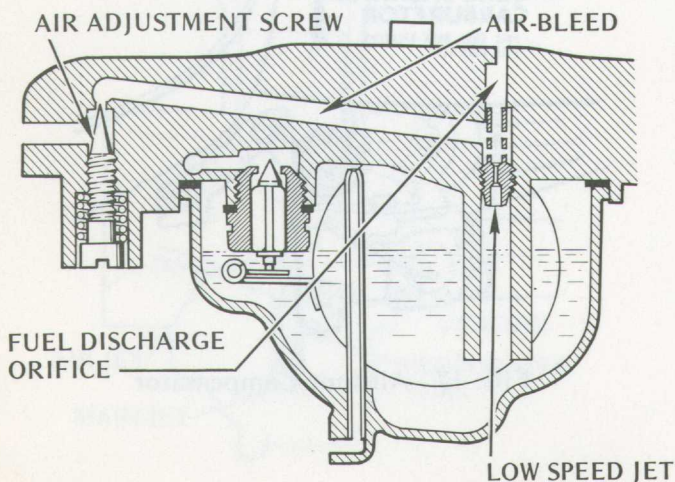

FIG. 19 Enlarged View of System

Fuel Discharge Orifices:

Some carburetors use a single fuel discharge orifice for both idle and low speed operation (Fig. 18 & 19), while others have separate idle and low speed orifices (Fig. 20 & 21). In either case, fuel is metered through the low speed jet and aerated before it reaches the fuel discharge orifice or orifices.

Carburetors using a single fuel discharge orifice (Fig. 18 & 19) have that orifice located at the lip of the throttle valve, where carburetor bore constriction and air speed are greatest.

Carburetors using separate idle and low speed orifices (Fig. 20 & 21) have the idle orifice located beyond the throttle valve, relying on intake port vacuum for fuel delivery. In this operating mode, the atomizer principle is not utilized; the throttle valve acts as a choke. When the throttle valve is opened slightly, the idle orifice continues to supply fuel, and the low speed orifice (or orifices) at the lip of the throttle valve are brought into play, supplying additional fuel to match the increased air flow.

IDLE AND LOW SPEED SYSTEM (continued)

Idle and Low Speed Air-Fuel Mixture Adjustment:

A screw type needle valve is provided for adjustment of the air-fuel mixture ratio. The adjustment screw can be located in the air-bleed passage leading to the low speed fuel jet or in the passage between the low speed fuel jet and the idle fuel discharge orifice.

If the adjustment screw is located in the air-bleed passage, as in Fig. 18 & 19, it will control the *flow rate of air* delivered to the perforated tube above the low speed fuel jet. The final air-fuel mixture ratio is achieved when the aerated pre-mixture is combined with the air in the carburetor bore. The adjustment screw is turned *clockwise to enrich* the mixture by reducing aeration, and vice versa.

If the adjustment screw is located in the passage between the low speed jet and the idle fuel discharge orifice, as in Fig. 20 & 21, it will control the *flow rate of aerated fuel* delivered to the carburetor bore. The final air-fuel mixture ratio is achieved when the aerated pre-mixture is combined with the air in the carburetor bore. The adjustment screw is turned *counterclockwise to enrich* the mixture by increasing fuel flow, and vice versa.

Major corrections in the idle and low speed air-fuel mixture ratio can be made by replacing the low speed jet. Replacement jets are available in graduated sizes to change the fuel flow rate. Select a larger jet diameter (higher jet number) to enrich the air-fuel mixture ratio or a smaller jet diameter (lower jet number) to produce a leaner mixture.

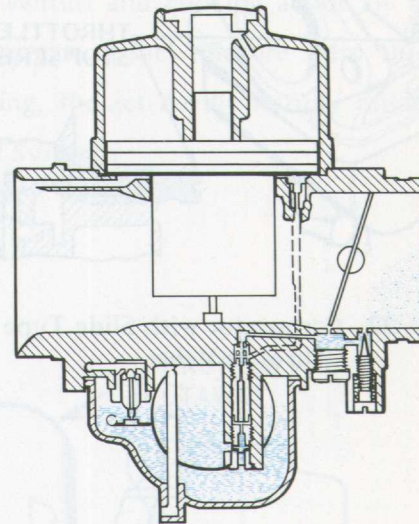

FIG. 20 Idle and Low Speed System with Fuel Adjustment Screw and Separate Fuel Discharge Orifices

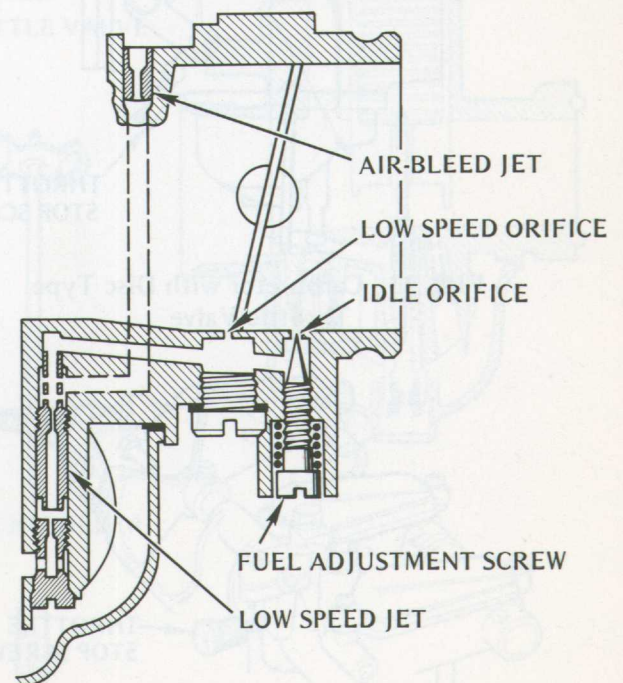

FIG. 21 Enlarged View of System

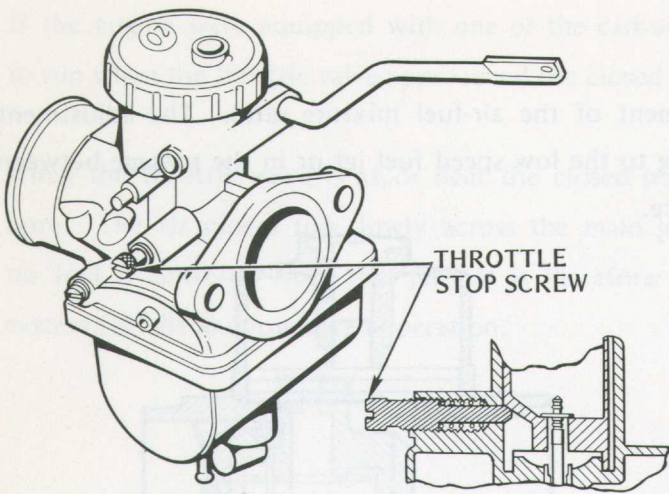

FIG. 22 Carburetor with Slide Type Throttle Valve

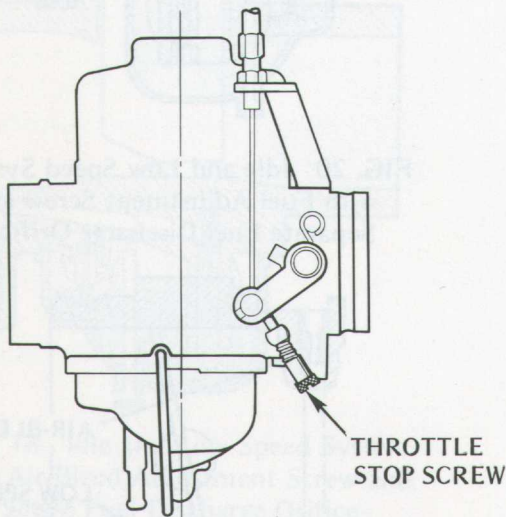

FIG. 23 Carburetor with Disc Type Throttle Valve

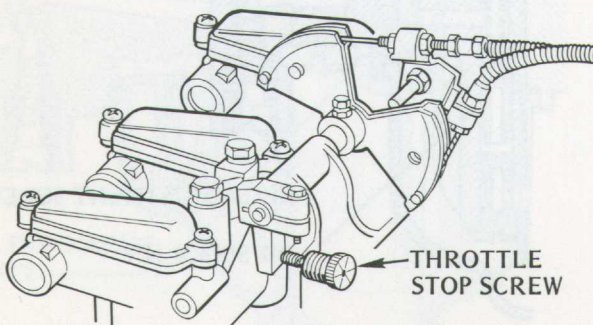

FIG. 24 Throttle Valve Linkage for Multiple Carburetors

Idle Speed Adjustment:

An adjustable throttle stop controls engine idle rpm by limiting throttle valve closure. The stop screw is turned clockwise to increase idle rpm or counterclockwise to decrease idle rpm.

If the carburetor is equipped with a slide type throttle valve, the stop screw will usually be located on the slide bore and act directly against the slide (Fig. 22).

A disc type throttle valve is more delicate and would be damaged if allowed to repeatedly strike a stop. Therefore, if the carburetor is equipped with a disc type throttle valve, the stop screw will usually be located at the throttle valve pivot arm (Fig. 23).

When carburetors on twin or multi-cylinder engines have individual throttle stops, idle speed adjustment requires precise equalization of each stop setting in order to maintain an identical throttle opening at each carburetor. The idle speed adjustment procedure is greatly simplified in certain models by providing a single throttle stop at the throttle valve operating linkage (Fig. 24). When a single throttle stop is used for two or more carburetors, throttle valve equalization is not affected by idle speed adjustment.

INTERMEDIATE SYSTEM WITH SLIDE TYPE THROTTLE VALVE

When the throttle valve is opened, there is a transition from the *Low Speed System* to an *Intermediate System* which meters fuel from the main fuel discharge jet (needle jet).

In carburetors with slide type throttle valves, the intermediate system uses a tapered fuel metering rod (jet needle) that works in connection with the variable venturi and choking action of the throttle valve. The jet needle meters fuel flow, maintaining the correct air-fuel mixture ratio through most of the carburetor's operating range. At full throttle opening, the jet needle is fully raised, and fuel flow will be controlled solely by main jet diameter (*High Speed System*).

Throttle Valve Cutaway:

The needle jet begins to discharge fuel at about 1/8 throttle opening and supplants the low speed system as the chief fuel supply. It is important to have a smooth transition from the low speed system to the intermediate system as the throttle is opened. Otherwise, there would be a momentary fuel delivery failure causing a flat spot in acceleration. The height of the throttle valve *cutaway* is crucial in obtaining smooth system transition and good initial acceleration.

While the position of the throttle slide determines the venturi constriction in the carburetor bore, the shape of the bottom edge of the slide determines the extent to which induction port vacuum is maintained at the needle jet.

The bottom edge of the slide, on the upstream side (air cleaner side) of the needle jet acts as a choke, but is *cut away* to a height that will produce the exact degree of choking needed to ensure proper fuel delivery from the needle jet at low throttle openings.

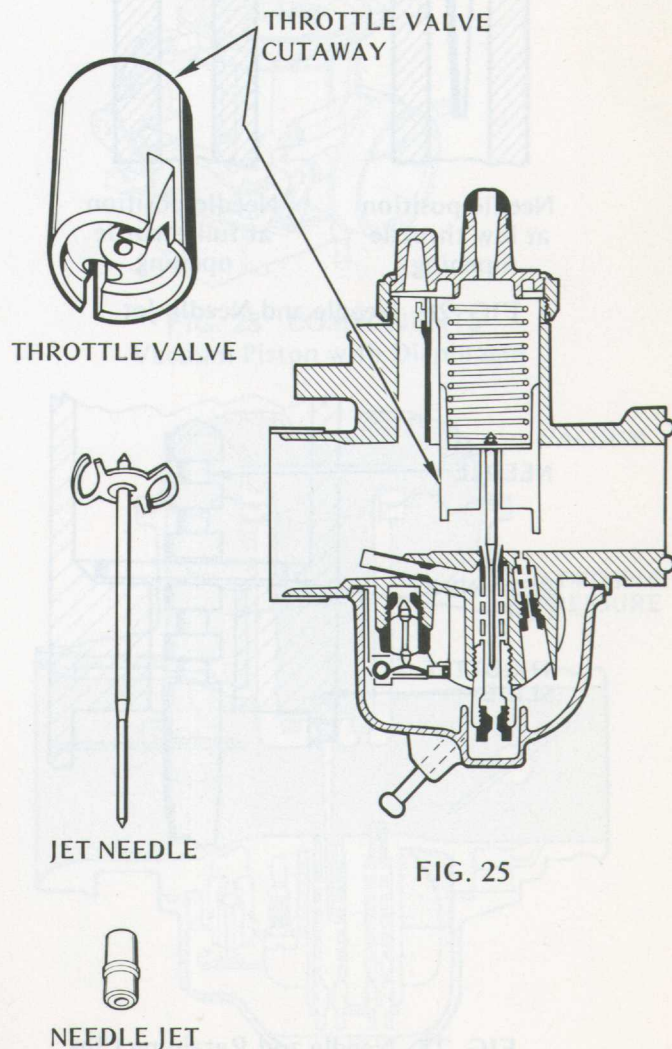

FIG. 25

INTERMEDIATE SYSTEM WITH SLIDE TYPE THROTTLE VALVE (continued)

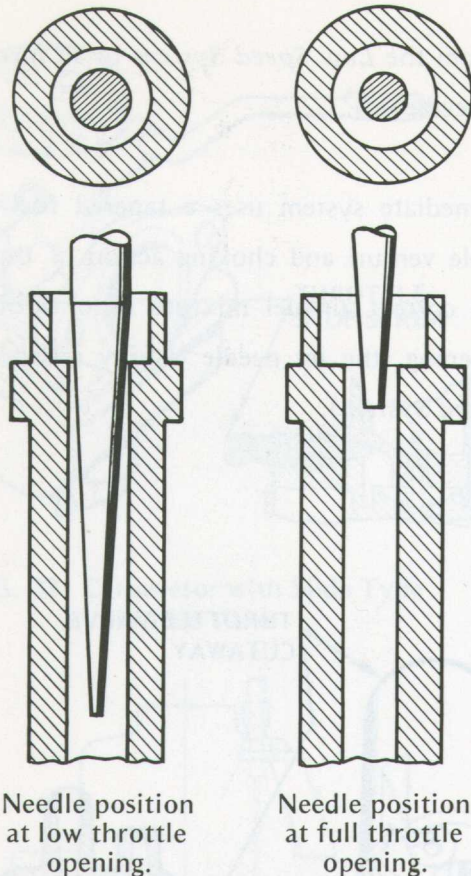

FIG. 26 Needle and Needle Jet

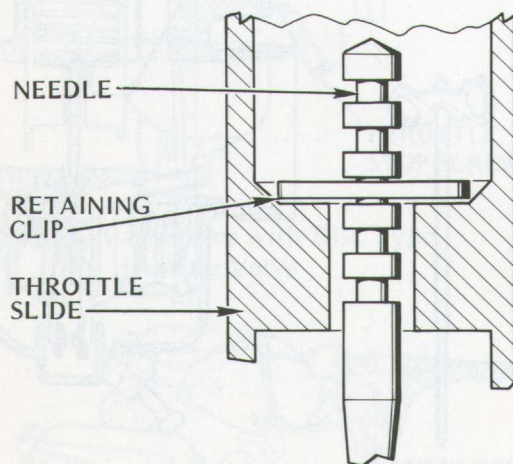

FIG. 27 Needle and Retaining Clip

Increasing the height of the cutaway reduces the choking effect, producing a leaner air-fuel mixture ratio, and vice versa.

The throttle valve cutaway controls the air-fuel mixture ratio primarily at 1/8 to 1/4 throttle openings and ceases to have any effect beyond a 1/2 throttle opening.

Jet Needle:

A tapered metering rod, called the *jet needle*, is attached to the throttle slide and extends downward into the fuel discharge jet (*needle jet*).

At low throttle openings, the wide base of the needle fills most of the fuel jet diameter, reducing fuel flow to a minimum. As the throttle valve is opened, raising the needle, the progressively smaller needle diameter allows more fuel to flow through the jet, matching the increasing volume of air flowing through the carburetor bore (Fig. 26).

Jet needles used with slide type throttle valves usually have a series of grooves at the needle head to permit alternate mounting positions. The jet needle can be raised or lowered in the throttle slide by installing the jet needle retaining clip (Fig. 27) in one of the alternate grooves.

Raising the needle to a higher mounting position allows a greater flow of fuel through the needle jet, creating a richer air-fuel mixture ratio. Lowering the needle creates a leaner air-fuel mixture ratio. The jet needle controls the air-fuel mixture ratio primarily at 1/4 to 3/4 throttle openings.

INTERMEDIATE SYSTEM WITH DISC TYPE THROTTLE VALVE AND VACUUM PISTON

As the disc type throttle valve is opened, there is a transition from low speed fuel discharge orifices to an intermediate system, similar to that which occurs in carburetors using slide type throttle valves. However, there is more accurate venturi control, as the vacuum piston moves independently.

When a *slide* type throttle valve is opened, the venturi constriction is widened in direct proportion to throttle opening, as these are functions of one integral part. If the slide throttle valve is mechanically linked to the throttle grip, venturi size is regulated by the rider, whose wishes will not necessarily coincide with the needs of the carburetor. An independently controlled vacuum piston (or a vacuum controlled slide throttle valve, see pages 23-24) ensures correct venturi size and air velocity throughout the intermediate operating range.

Vacuum Piston Construction:

The bottom of the vacuum piston is vented to allow air pressure in the carburetor bore and air pressure in the chamber above the vacuum piston to equalize. The chamber below the vacuum piston diaphragm or rim is vented to the atmosphere.

Vacuum piston design may utilize a diaphragm to separate the upper and lower air chambers (Fig. 28 & 29). Designs which do not utilize a diaphragm rely on a close fit between the piston and the walls of the carburetor top to separate the air chambers (Fig. 30 & 31).

When air pressure in the carburetor bore becomes significantly lower than atmospheric pressure, atmospheric pressure forces the piston upward. When air pressure in the carburetor bore approaches atmospheric pressure, the piston will then fall of its own weight, sometimes assisted by a return spring.

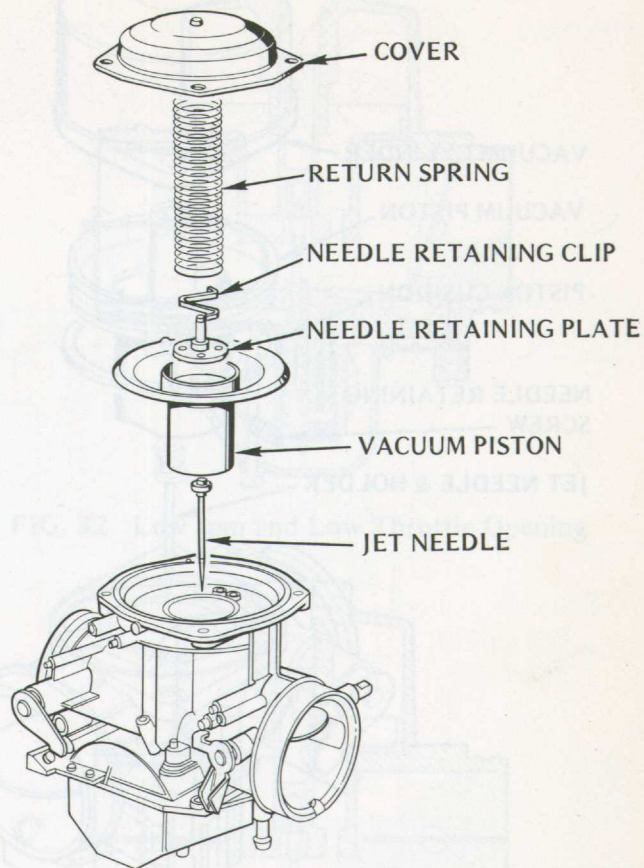

FIG. 28 COMPONENTS
Vacuum Piston with Diaphragm

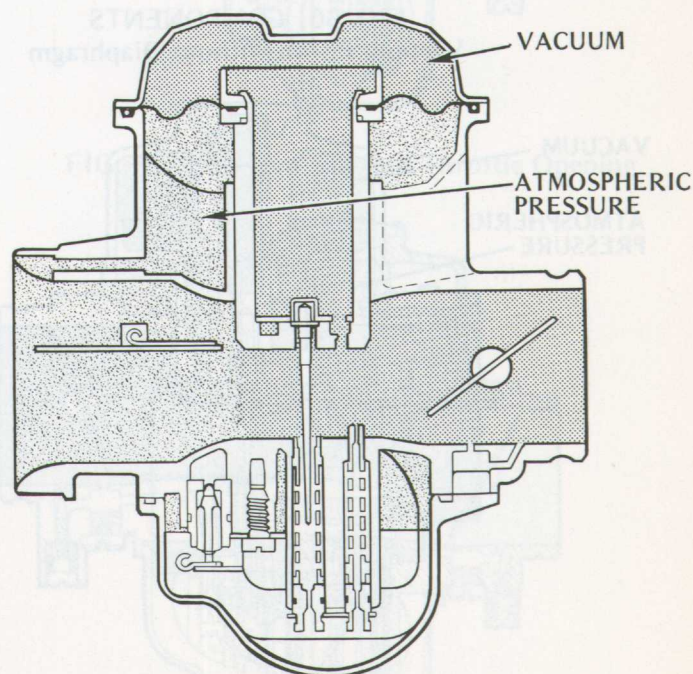

FIG. 29 OPERATION
Vacuum Piston with Diaphragm

INTERMEDIATE SYSTEM WITH DISC TYPE THROTTLE VALVE AND VACUUM PISTON (continued)

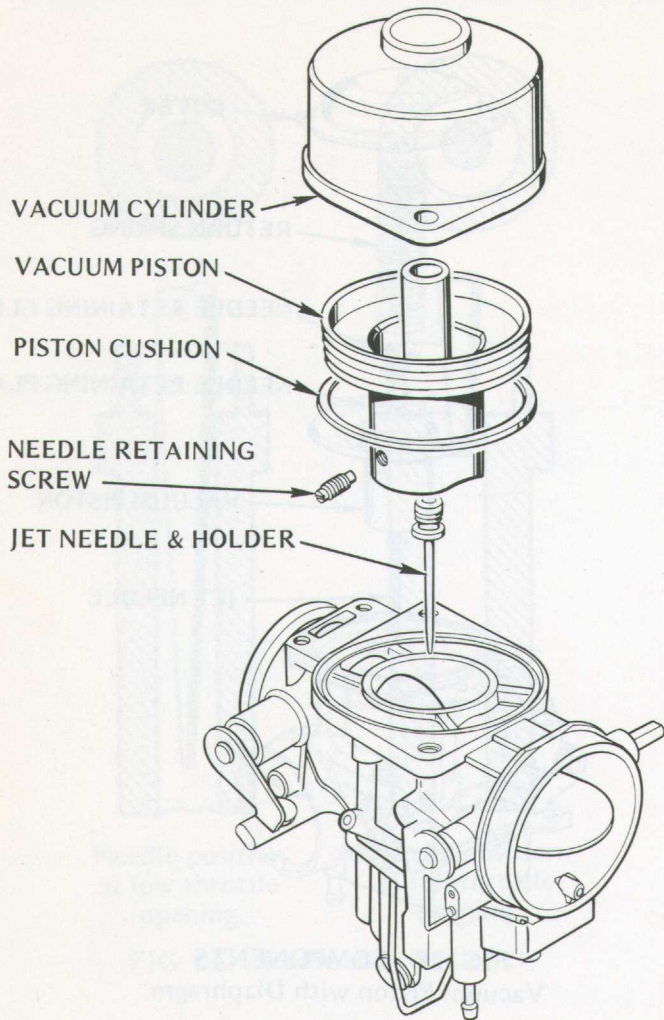

FIG. 30 COMPONENTS
Vacuum Piston without Diaphragm

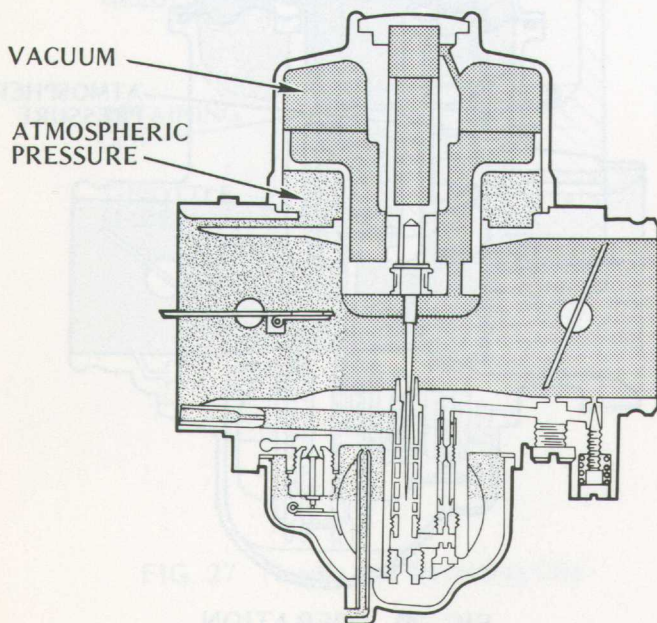

FIG. 31 OPERATION
Vacuum Piston without Diaphragm

Diaphragm type vacuum pistons have return springs to ensure closure because additional pressure is required to flex the diaphragm. Non-diaphragm type vacuum pistons fall freely and do not require return springs for positive closure. Non-diaphragm type vacuum pistons are sometimes fitted with return springs in order to modify the piston's operating characteristics. Adding a return spring has the same effect as increasing the weight of the piston.

Vacuum Piston Operation:

During idle and low speed operation, when the throttle valve is nearly closed, induction port vacuum is confined to the area downstream of the throttle valve. Air pressure at the vacuum piston is nearly the same as atmospheric pressure, and the vacuum piston is in the fully closed position (Fig. 32).

As the throttle valve is opened, the area under induction port vacuum extends upstream to the vacuum piston. The intermediate system becomes operative, and the vacuum piston moves in response to differences between atmospheric pressure and vacuum in the carburetor bore. Piston movement stabilizes at a height where the pressure differential balances piston weight (Fig. 34).

As engine rpm increases, the *volume* of air passing through the carburetor bore also *increases*. The *velocity* of air passing through the venturi *remains constant*, however, throughout the operating range of the vacuum piston.

An increase in flow volume is accommodated by increasing the size of the air passage rather than by increasing air *speed*. Piston movement varies the size of the venturi so that air velocity can remain constant regardless of changes in flow volume. Carburetors equipped with vacuum pistons are therefore frequently referred to as "constant velocity carburetors."

INTERMEDIATE SYSTEM WITH DISC TYPE THROTTLE VALVE AND VACUUM PISTON (continued)

Acceleration:

The main advantage of constant velocity carburetors is apparent during hard acceleration. If a motorcycle is equipped with conventional slide throttle carburetors, sudden full throttle opening at low speed may produce poor engine response, as vacuum and venturi air velocity will drop to a point where very little fuel is drawn from the jets. If the motorcycle is equipped with constant velocity carburetors, the vacuum pistons ensure sufficient venturi air velocity to prevent a lean fuel mixture on sudden throttle opening.

In automotive applications, the vacuum piston may be equipped with an oil damper to retard upward movement of the piston for a richer acceleration mixture. Alternatively, an automotive carburetor may use an "accelerator pump" which squirts additional fuel into the carburetor bore on sudden throttle opening.

Jet Needle:

Because venturi air velocity is held to a constant speed, air pressure against the fuel jet nozzle(s) is also constant. This causes the fuel to tend to flow from the jet(s) at a constant rate, regardless of engine rpm, so the vacuum piston must carry a metering rod (jet needle) to regulate fuel flow in proportion to air flow volume.

Jet needles used in constant velocity carburetors are similar to those used in slide throttle carburetors, except that most models of constant velocity carburetors do not provide any needle height adjustment. Fuel mixture adjustment for the intermediate operating range is achieved by replacing the main jet(s) with jets of larger or smaller diameter. In some cases, replacement needles with other profiles may be available to alter the fuel flow rate.

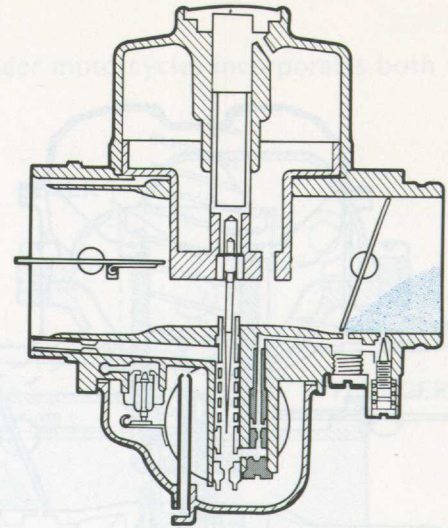

FIG. 32 Low rpm and Low Throttle Opening

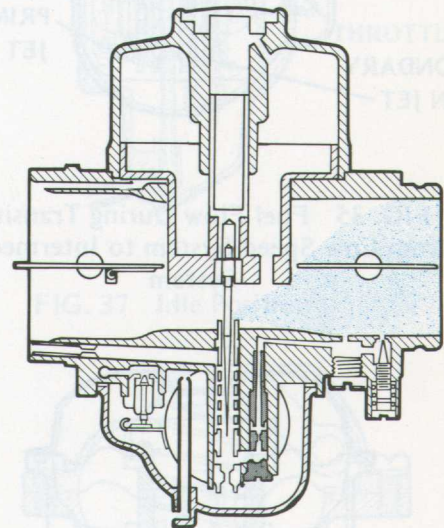

FIG. 33 Low rpm and Full Throttle Opening

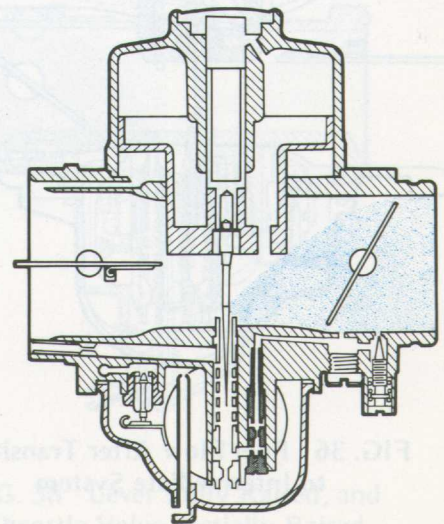

FIG. 34 Intermediate rpm and Intermediate Throttle Opening

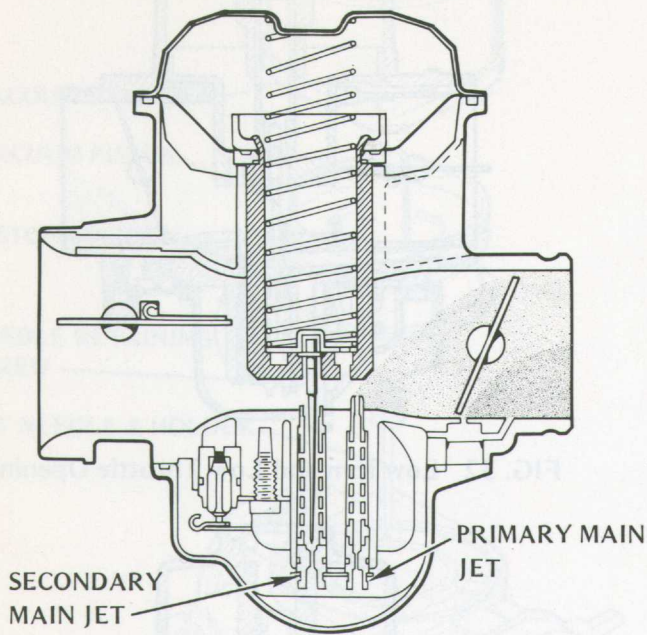

FIG. 35 Fuel Flow During Transition from Low Speed System to Intermediate System

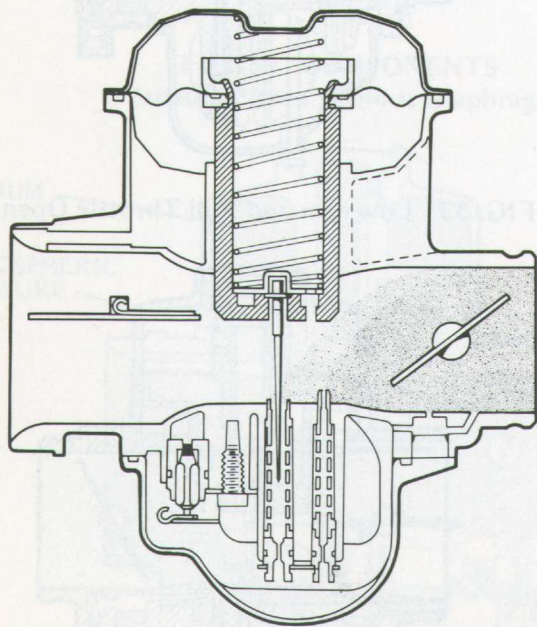

FIG. 36 Fuel Flow After Transition to Intermediate System

Single Main Fuel Circuit:

The carburetor illustrated in Fig. 32, 33, & 34 discharges fuel from a single jet assembly throughout the operating range of the intermediate and high speed systems. Main jet and needle jet functions are similar to those in carburetors with slide type throttle valves.

Primary and Secondary Main Fuel Circuits:

The carburetor illustrated in Fig. 35 & 36 divides the main jet system into primary and secondary circuits. The purpose of this design is to provide a smoother transition from low speed to intermediate systems.

As the throttle valve starts to open and induction port vacuum extends upstream, fuel is discharged from the primary main jet nozzle before the secondary circuit becomes operative (Fig. 35).

As the throttle valve opens farther, fuel is discharged from the secondary main jet nozzle (needle jet), and the vacuum piston begins to rise (Fig. 36).

Fuel is delivered from both primary and secondary circuits throughout the operating range of the vacuum piston. Fuel mixture adjustment can be made by replacing the main jets with jets of larger or smaller diameter.

INTERMEDIATE SYSTEM WITH COMBINATION SLIDE TYPE THROTTLE VALVE/VACUUM PISTON

The carburetor used in Honda SS-125 and CL-125 twin cylinder motorcycles incorporates both throttle and vacuum piston functions in a single slide valve assembly.

Construction:

Air chambers above the throttle slide/vacuum piston are divided by a diaphragm. The throttle grip at the handlebar operates a lever which limits upward movement of the throttle slide and controls the position of a plunger valve within the slide. The plunger valve vents the air chamber above the diaphragm to atmospheric pressure when the plunger is depressed, and to induction port vacuum when the plunger is released. The air chamber below the diaphragm is always vented to the atmosphere.

Operation:

When the lever is fully lowered, the throttle slide is held in the idle position. The plunger valve within the slide is depressed, venting the upper air chamber to atmospheric pressure, so the slide will not resist closure (Fig. 37).

When the lever is raised, the plunger valve is released, venting the upper air chamber to induction port vacuum. The throttle slide then rises in response to differences between atmospheric pressure and vacuum in the carburetor bore. When the throttle slide rises, fuel is discharged from the needle jet (Fig. 38).

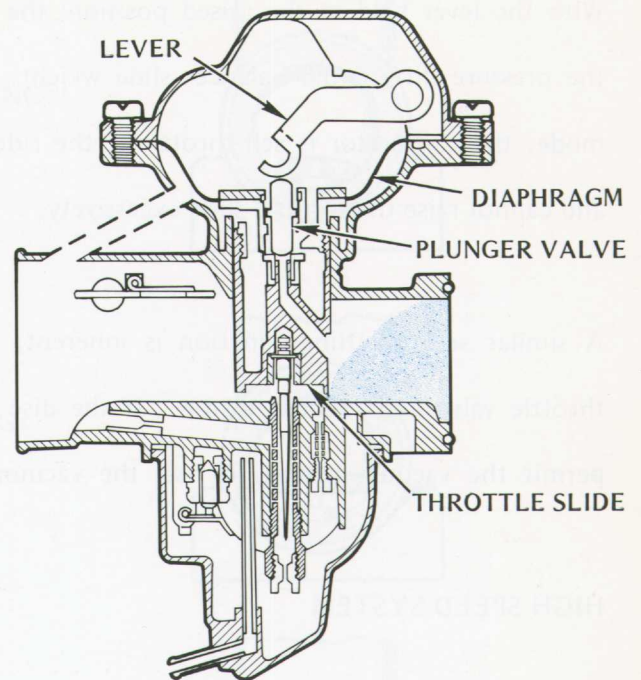

FIG. 37 Idle Position

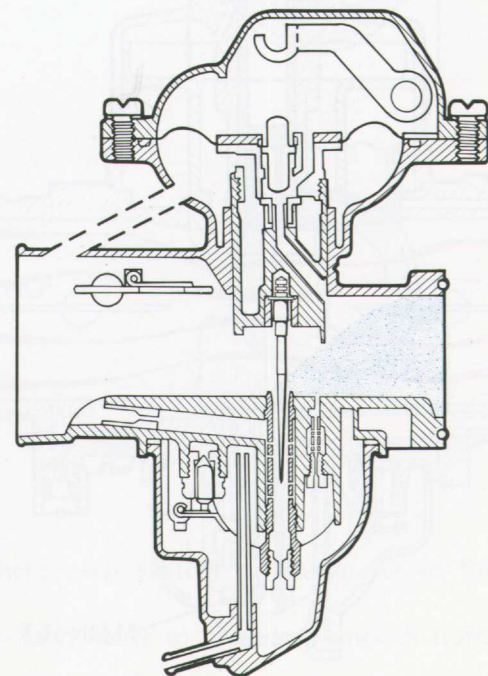

FIG. 38 Lever Fully Raised, and Throttle Valve Partially Raised

INTERMEDIATE SYSTEM WITH COMBINATION SLIDE TYPE THROTTLE VALVE/VACUUM PISTON (continued)

With the lever held in the raised position, the throttle slide will rise until it stabilizes at a height where the pressure differential balances slide weight, or until the plunger contacts the lever. In this operating mode, the carburetor is self-throttling; the rider controls only the upward *limit* of throttle slide travel and cannot raise the throttle slide excessively.

A similar self-throttling function is inherent, though less obvious, in carburetors with a separate disc throttle valve and vacuum piston. If the disc throttle valve is opened farther than pressure differences permit the vacuum piston to rise, the vacuum piston temporarily assumes the function of a throttle.

HIGH SPEED SYSTEM

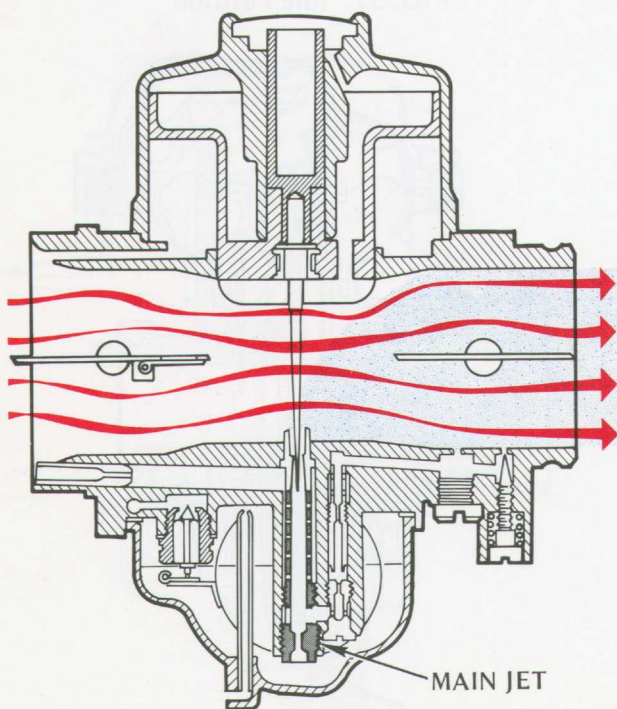

FIG. 39 High Speed System

When the throttle valve is fully open, and the vacuum piston (if so equipped) is fully raised, the carburetor functions as an elementary fixed venturi instrument. Compare the high speed system illustrated in Fig. 41 with the elementary carburetor illustrated in Fig. 2, page 4.

Fuel mixture is controlled by the size of the main jet. The fully raised jet needle does not appreciably restrict the flow of fuel at the jet needle. Fuel mixture adjustment is achieved by replacing the main jet(s) with jets of larger or smaller diameter.

FUEL MIXTURE CONTROL IN RELATION TO THROTTLE POSITION

FIG. 40 IDLE TO 1/8 THROTTLE OPENING:

Idle and low speed system controls fuel mixture.

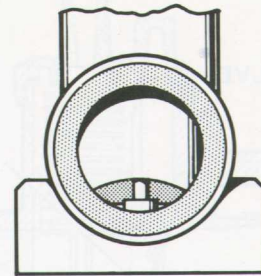

FIG. 41 1/8 TO 1/4 THROTTLE OPENING:

Throttle valve cutaway controls fuel mixture.

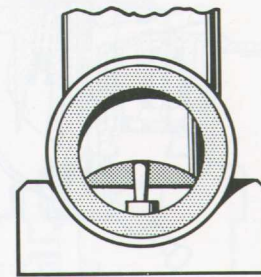

FIG. 42 1/4 TO 3/4 THROTTLE OPENING:

Jet needle controls fuel mixture.

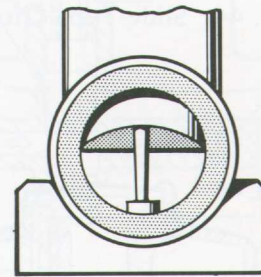
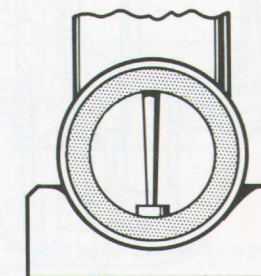

FIG. 43 3/4 TO FULL THROTTLE OPENING:

Main Jet controls fuel mixture.



The above illustrations show the throttle position where each system predominates in fuel mixture control. The operating ranges of these systems overlap each other to provide a smooth transition from one system to another.

COLD STARTING SYSTEM

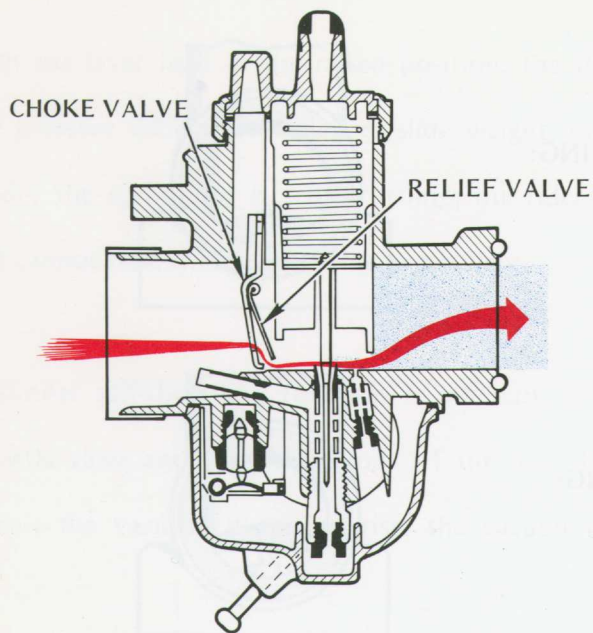

FIG. 44 Slide-Type Choke Valve

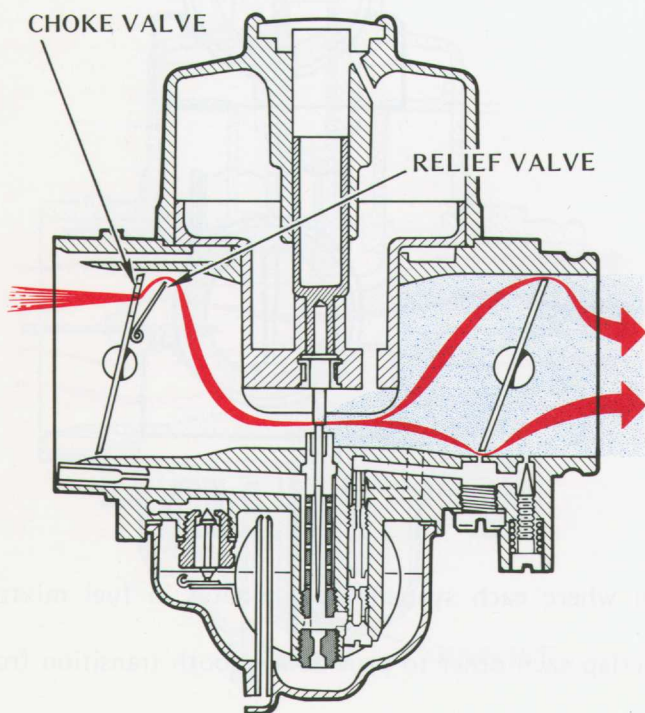

FIG. 45 Pivoted Disc-Type Choke Valve

Fuel does not vaporize well in a cold engine and tends to condense on intake port and cylinder walls. Because a smaller percentage of the fuel is vaporized in a cold engine, the carburetor must deliver a richer mixture in order for the combustion chamber to have enough vaporized fuel to make a combustible air-fuel mixture. The mixture must not be excessively enriched, however, or the combustion chamber will become flooded with liquid fuel which may not ignite.

The cold starting system used in Honda motorcycles may be either a supplemental fuel delivery circuit (Mixture Enrichener) or a choke valve that enriches the mixture by obstructing the carburetor bore (see Choke Effect, pages 4-5).

Choke Valve:

A choke valve is the most commonly used cold starting device. In motorcycle carburetors, it may be either a flat slide (Fig. 44) or a pivoted disc (Fig. 45). The choke valve is connected to a lever or knob by which the rider controls the choke valve position.

When the choke valve is closed, it reduces the volume of air that can flow through the carburetor bore to fill the vacuum created in the engine cylinder, thus maintaining a partial vacuum at all fuel discharge jets and orifices. Atmospheric pressure in the float chamber then forces more fuel into the carburetor bore. A spring loaded relief valve within the choke slide or disc limits carburetor bore vacuum to a certain level to reduce the possibility of flooding.

COLD STARTING SYSTEM (continued)

Mixture Enrichener:

A mixture enrichener is used in Honda two-stroke motorcycles instead of a choke valve in order to improve fuel atomization and further reduce the possibility of flooding. A plunger valve, controlled by an external lever or knob, opens or closes a supplemental fuel delivery circuit (Fig. 46). The valve is either fully open or closed; there is no provision for partial opening positions.

When the valve is open, the mixture enriching circuit functions like an atomizer (see Atomizer Principle, page 3). Fuel flows from the float bowl through a metering jet, then through a perforated tube where the fuel is initially aerated. When the aerated fuel reaches the enrichener valve juncture, it is combined with the airstream in a passage that parallels the carburetor bore. The mixture is then sprayed into the carburetor bore at a point downstream from the throttle slide.

The throttle slide must be closed for the mixture enrichener circuit to be fully effective. A closed throttle slide maintains a high vacuum at the discharge port of the mixture enrichener, and air rushes through the mixture enrichener air passage to fill that vacuum. Raising the throttle slide causes a loss of vacuum at the discharge port and diminishes the mixture enrichener airstream.

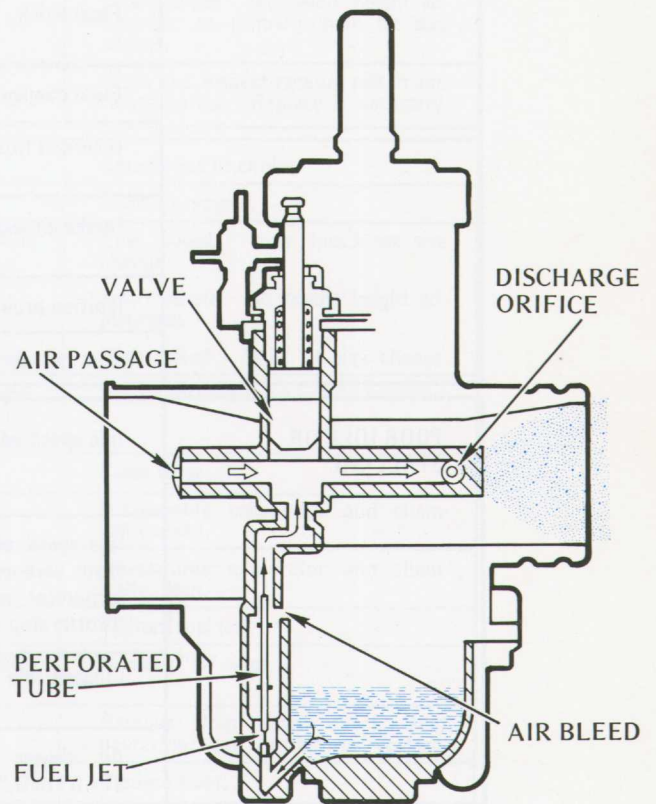

FIG. 46 Mixture Enrichener Circuit

CARBURETOR TROUBLESHOOTING CHART

PROBLEM	POSSIBLE CAUSE	CORRECTION
HARD STARTING.	Incorrect use of choke.	Correct use of choke.
	Incorrect air-fuel mixture adjustment.	Set mixture adjustment screw in accordance with owner's manual or shop manual instructions.
	Clogged fuel filter.	Clean filter.
	Clogged low speed fuel jets.	Disassemble carburetor and chemically clean.
	Clogged vent in fuel tank cap.	Unclog vent or replace cap.
	Float stuck.	Remove float bowl, check float operation, and correct or replace.
	Float damaged or leaking.	Replace float.
	Incorrect float level.	Set float height in accordance with shop manual specifications.
	Intake air leak.	Check carburetor mounting flanges for air leaks.
	Ignition problem.	Repair, replace, or adjust as necessary.
	Low cylinder compression.	Repair, replace, or adjust as necessary.
POOR IDLE OR STALLING.	Idle speed adjustment(s) set too low.	Adjust idle rpm in accordance with specifications in owner's manual or shop manual.
	Idle speed adjustments are unequal (twin carburetor models and multi-carburetor models using individual throttle stop adjustments).	Equalize throttle stop settings.
	Clogged idle & low speed air bleed.	Disassemble carburetor and chemically clean.
	All causes listed under "HARD STARTING."	
IDLE MIXTURE ADJUSTMENT IS INEFFECTIVE. CARBURETOR DOES NOT RESPOND TO MOVEMENT OF THE IDLE MIXTURE SCREW.	Idle speed set too high.	Adjust idle speed in accordance with specifications in owner's manual or shop manual.
	Clogged low speed air-bleeds.	Disassemble carburetor and chemically clean.
	Damaged mixture adjustment needle.	Replace mixture adjustment needle.
	Mixture adjustment needle "O" ring is not sealing (models using "O" ring).	Replace "O" ring.
	Damaged mixture adjustment needle seat.	Replace carburetor.
	All carburetor problems listed under "HARD STARTING."	

PROBLEM	POSSIBLE CAUSE	CORRECTION
SLOW RETURN TO IDLE.	Idle speed set too high.	Adjust idle speed in accordance with specifications in owner's manual or shop manual.
	Idle speed adjustments are unequal (twin carburetor models and multi-carburetor models using individual throttle stop adjustments).	Equalize throttle stop settings.
	Throttle valve sticking.	Clean and inspect throttle valve and return spring. Replace if necessary.
	Throttle linkage sticking.	Clean and inspect throttle linkage and return spring. Lubricate, repair, or replace as necessary.
	Throttle cable binding.	Correct routing or replace cable as necessary.
ENGINE SURGES WHEN CRUISING AT A CONSTANT SPEED.	Incorrect air-fuel mixture adjustment.	Low Speed - Low speed jet size change. Intermediate - Jet needle height adjustment or primary main jet size change.
	Vacuum piston sticking.	Clean and inspect vacuum piston and return spring. Replace if necessary.
ENGINE DOES NOT DEVELOP FULL POWER, OR MISSES ON ACCELERATION.	Incorrect use of choke.	Correct use of choke.
	Clogged air cleaner.	Clean or replace.
	Incorrect air-fuel mixture adjustment.	Low Speed - Low speed jet size change. Intermediate - Jet needle height adjustment. High Speed - Main jet size change.
	Throttle valves not synchronized (models with two or more carburetors).	Adjust throttle valve synchronization.
	Clogged fuel filter.	Clean filter.
	Clogged fuel jets.	Disassemble carburetor and chemically clean.
	Clogged air bleeds.	Disassemble carburetor and chemically clean.
	Fuel jets loose.	Tighten fuel jets.
	Fuel jet "O" rings leaking (models using "O" rings).	Replace "O" rings.
	Float stuck.	Remove float bowl, check float operation, and correct or replace.
	Float damaged or leaking.	Replace float.
	Incorrect float level.	Set float height in accordance with shop manual specifications.
	Vacuum piston sticking.	Clean and inspect vacuum piston and return spring. Replace if necessary.
	Vacuum piston diaphragm ruptured.	Replace vacuum piston assembly.
	Ignition problem.	Repair, replace, or adjust as necessary.
Low cylinder compression.	Repair, replace, or adjust as necessary.	

NOTE: It may be necessary to change carburetor jets to correct the air-fuel mixture ratios under the following circumstances:

- Exhaust system modifications
- Air cleaner alteration or removal
- Altitude changes
- Temperature and humidity changes